

Shore-Power Heating Kit Manual



Volta
Power Systems

! CAUTION !

Volta Power Systems recommends this kit be installed by a qualified technician.

Care should be taken to ensure the instructions are followed completely.

Volta is not responsible for any personal injury or damage which may occur due the improper installation of this kit.

TABLE OF CONTENTS

1.0 Shore-Power Heating Kit Overview 4

 1.1 Intended Use..... 4

 1.2 Materials Needed For Install..... 4

 1.3 KL and GL Applications..... 4

 1.4 Safety Recommendations  5

2.0 Volta Heating Pad Retrofit Kit 6

 2.1 Contents..... 6

3.0 Wiring Diagram..... 7

4.0 KL Installation..... 8

5.0 GL Installation 18

1.0 SHORE-POWER HEATING KIT OVERVIEW

1.1 INTENDED USE

The *Volta Heating Pad Retrofit Kit* is intended to be used with Travato systems that have not already been outfitted with a heating pad system. The system is compatible with Travato KL/GL model years 2019 and 2020. Volta highly recommends the install be completed at a Winnebago dealer or repair facility. Volta Power Systems is not held responsible for any damage incurred during the retrofitting process.

1.2 MATERIALS NEEDED FOR INSTALL

The following materials should be acquired before starting the retrofit process

Required Tools and Supplies:

- (x2) RTV Sealant 3oz packages (Permatex® Black Silicone Adhesive Sealant or comparable)
- Electrical Tape
- Wire Stripper (for use with 18AWG wire)
- Phillips-Head Screwdriver
- Utility Knife
- Degreasing Solvent and Cleaning Cloth
- Volta Shore-Power Heating Kit

1.3 KL AND GL APPLICATIONS

The Travato KL and GL have different install requirements based on component location in the vehicle. The estimated install time for the Travato KL is ~45minutes. The estimated install time for the Travato GL is ~6 hours. Please allow for adequate install time based on the vehicle type being modified. It is recommended that all instructions are read thoroughly, and appropriate supplies acquired before attempting installation of the heating pad.

1.4 SAFETY RECOMMENDATIONS



- (1) Do not make any alterations involving the Volta System while the system is powered on. Ensure power to the system is off before any modifications are made. Working on a live system could cause damage to the system, or injury to those working on it.
- (2) Do not modify any wires, or system components that are not specifically called out in this manual. Modifying wires or system components could lead to damage of the Volta system or vehicle.
- (3) Read and understand this installation manual before attempting the install process
- (4) Acting outside of the actions called out in this manual will void the Volta System warranty. It is recommended that only Volta approved dealers make the modifications outlined in this manual.



The use of this symbol is used to denote a safety critical component of the manual and should be given complete attention to ensure that information, in any section, is completely understood.

2.0 VOLTA HEATING PAD RETROFIT KIT

2.1 CONTENTS

After receiving the *Shore-Power Heating Kit*, unpack the contents to ensure all pieces are present and in undamaged condition.

- 20ft AC Extension Cord
- Female Grounded AC Plug
- 2 Conductor Heater Line Extension
- Corrugated Split Loom (Wire protectant)
- Diode Wire Assembly
- Heating Pad
- Double Outlet Heater Box Assembly
- Zip Ties
- Wood Screws
- Fiberglass Sheets

3.0 WIRING DIAGRAM

The wiring for the overall installation is shown in Figure 1.

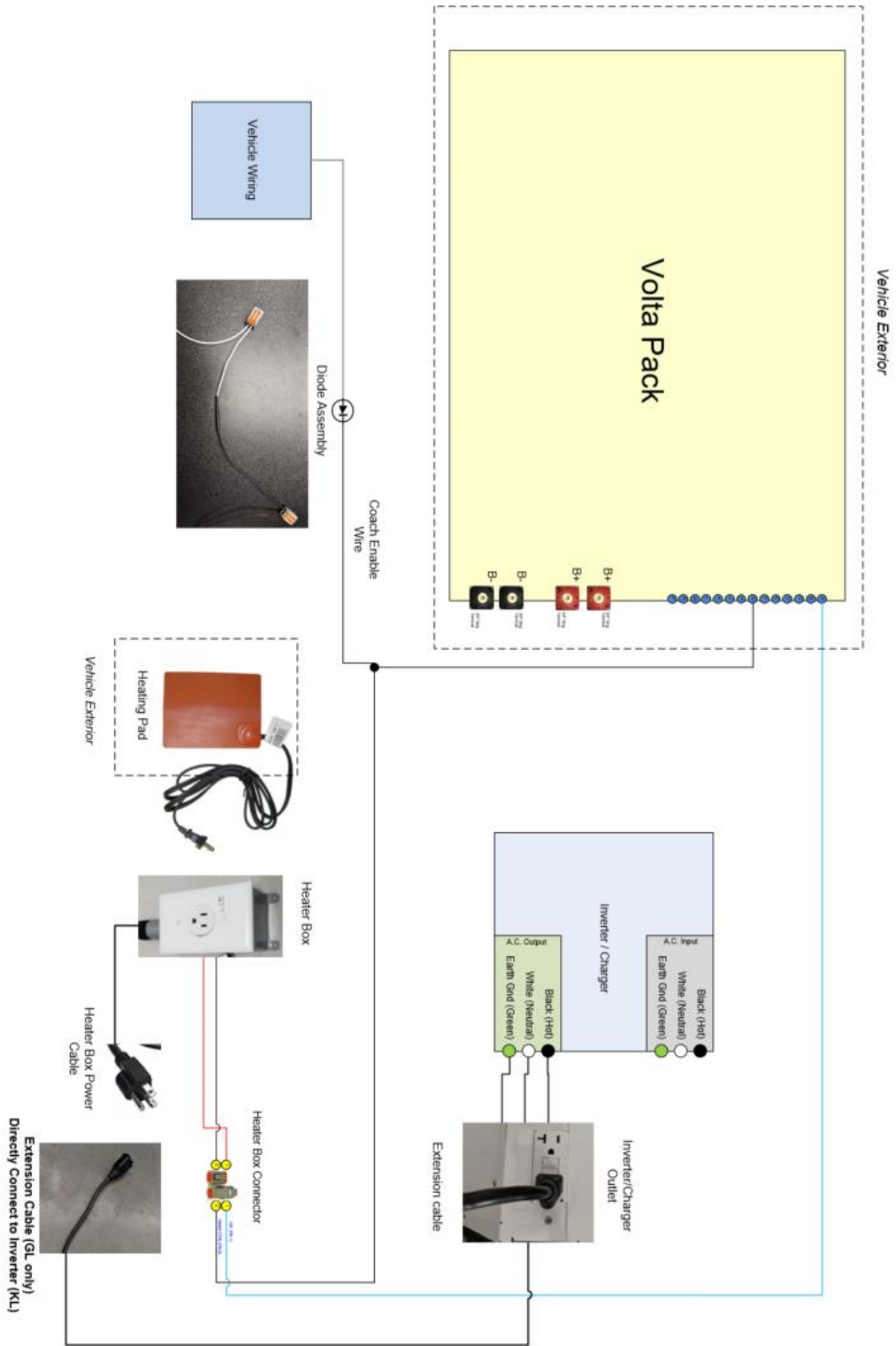

Figure 1: Heating Pad Wiring Diagram

4.0 KL INSTALLATION

Due to system location in the KL, multiple components included in the heating pad kit will be unused during the installation. The AC extension cord, split loom, and 2 Conductor Heater Line Extension, can be placed to the side as they will not be needed for this installation.

- 1) To begin installation, start by ensuring the Volta system has been powered off, along with the vehicle. Next, locate the Volta Pack access cover which is positioned under the vehicle, behind the rear axle (Figure 2,3).

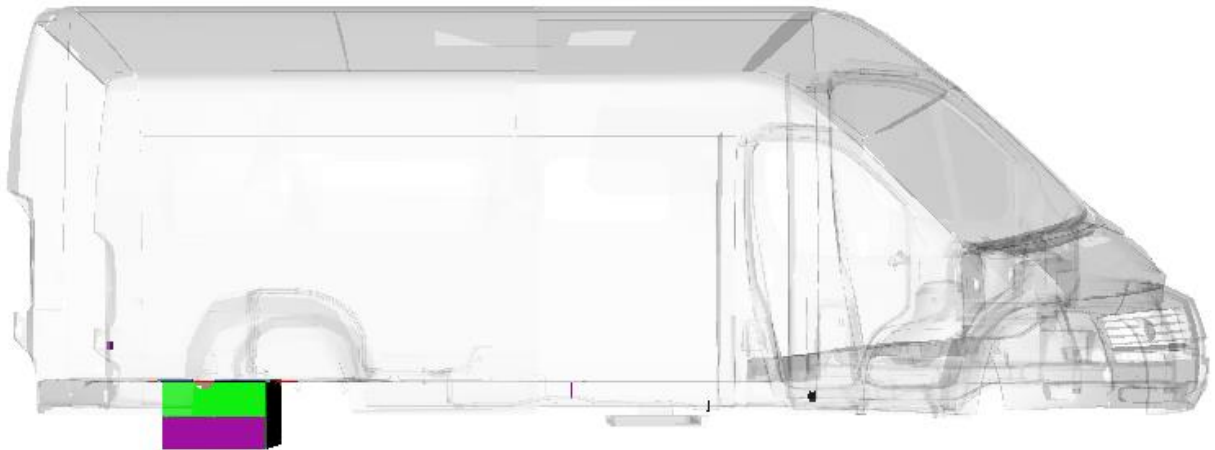

Figure 2: Volta Pack Location

- 2) Uninstall the access cover by using a Phillips-head screwdriver to remove the 8 mounting screws (Figure 2,3).

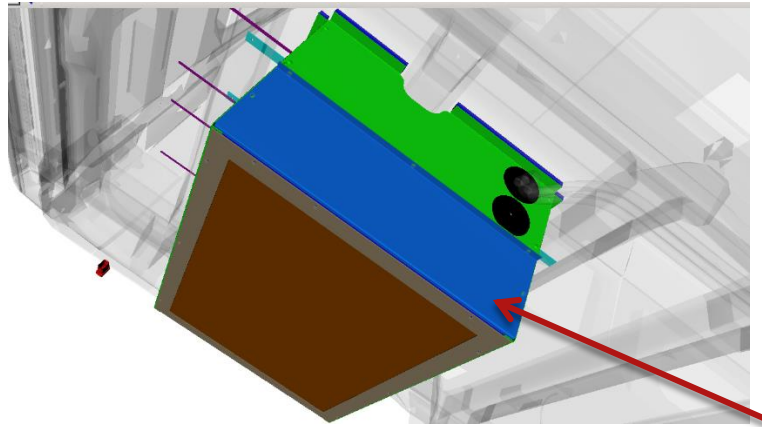

Figure 3: Volta Pack Access Cover (Blue) and Lower Battery Panel (Brown)

- 3) Turn the pack key into the vertical, OFF, position and remove it until the end of the modification (Figure 4). Then disconnect the round trunk connector from the pack (Figure 5).



Figure 4: Key in vertical "Off" Position



Figure 5: Round Trunk Connector

- 4) Remove the lower panel from the battery case that is held in-place with 9 Phillips-head screws (Figure 3).
- 5) On the inside of the vehicle, remove the twin mattress on the passenger side of the vehicle and locate the screws holding down the bed platform and white storage tub. Remove the screws and lift off the platform, and storage tub, to access the cabinets underneath. (Figure 6).

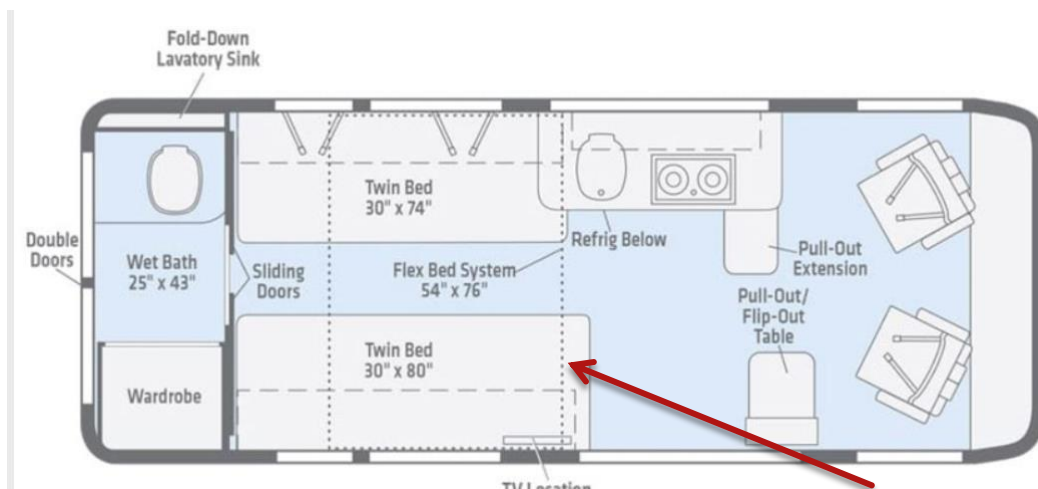

Figure 6: Twin Mattress Location with Access Cabinets Below

- 6) From inside the cabinet, closest to the bath, drop down the heating pad into the Volta pack compartment under the vehicle (Figure 7). Ensure that the plug end of the heating pad stays inside the cabinet.

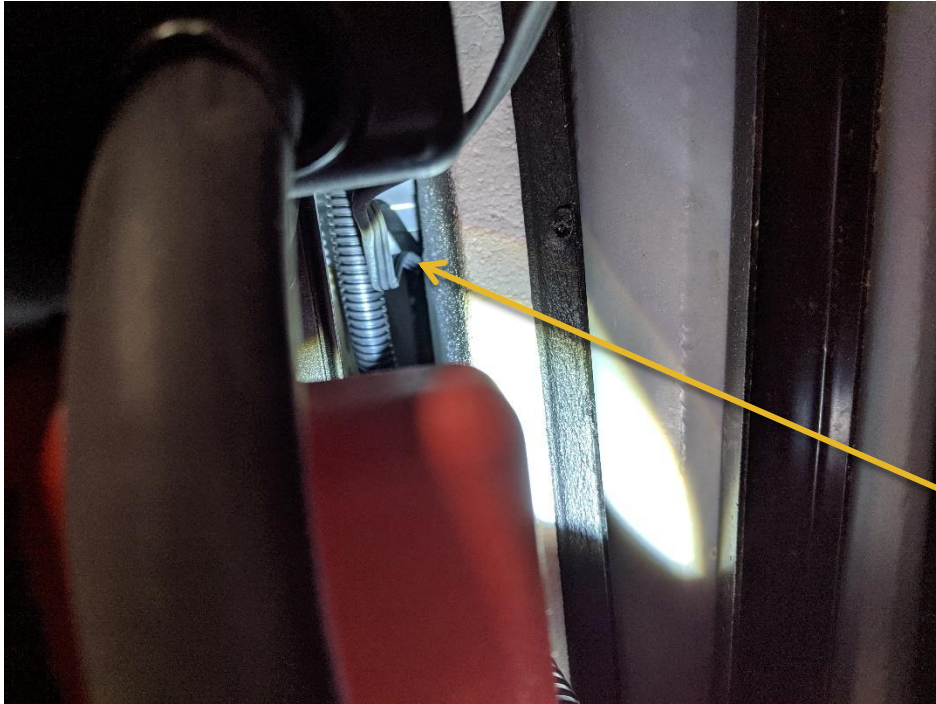

Figure 7: Slot to Feed Down Heating Pad

- 7) Take the heater box and attach it to the cabinet wall using the included wood screws (Figure 8). The AC plug left in the compartment, from the heating pad, can be plugged into the heater box. The heater box 2-pin connector can be attached to the mating connector that is already located in the cabinet (Figure 9).



Figure 8: Cabinets Below Passenger Side Twin Bed

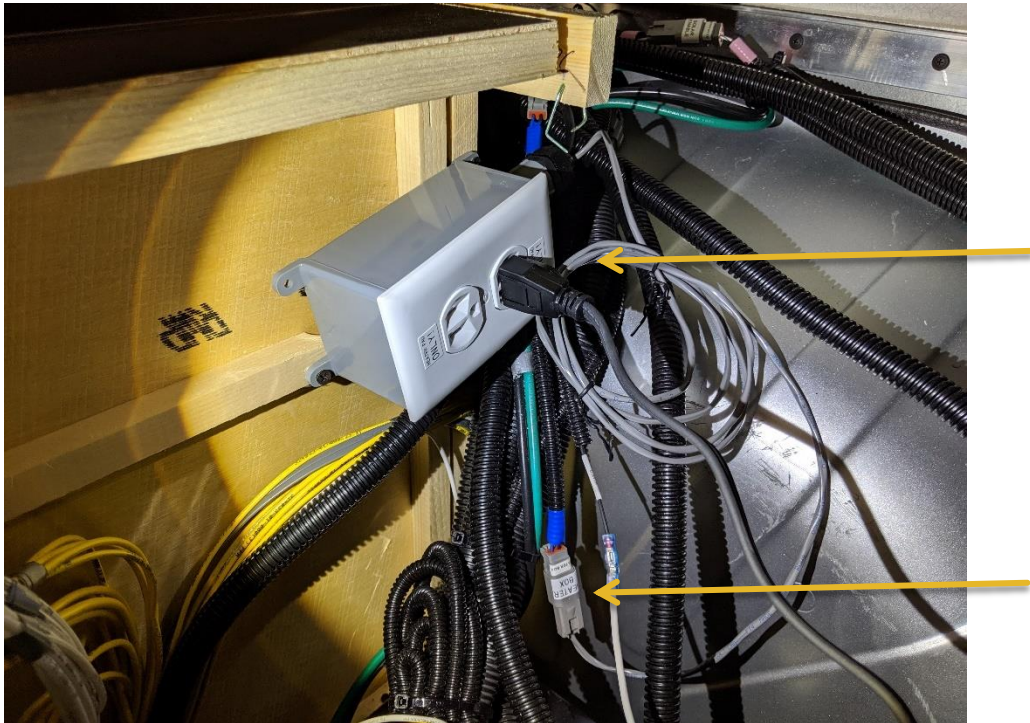

Figure 9: Attachment Location for the Heater Box, Heating pad plugged in, 2-pin heater box connector plugged in.

- 8) Next, feed the heater box AC power cord along the wheelwell behind the cabinets. Pull the cord into the cabinet which houses the inverter/charger and plug the AC power cord into the GFCI outlet (Figure 10).



Figure 10: Heater Box Plugged into Inverter/Charger GFCI Outlet

- 9) Find the black wire labeled “Coach Heater” that is spliced to a white wire (Figure 11). The splice should be located in the wire bundle located in the cabinet where the heater box has already been installed. Remove the butt splice by cutting both sides of the wire. Strip the ends of both the white and black wire.



Figure 11: Coach Heater Line Splice

10) Take the diode assembly, included in your kit, and align the white and black wires to match the same colored wire in the vehicle (Figure 12,13). Pull the orange tabs up on the unused Wago connector terminals. Insert the stripped wire ends from the vehicle into the corresponding connector terminal. Pull the orange levers down to lock in the connection (Figure 13).



Figure 12: Diode Assembly from Kit

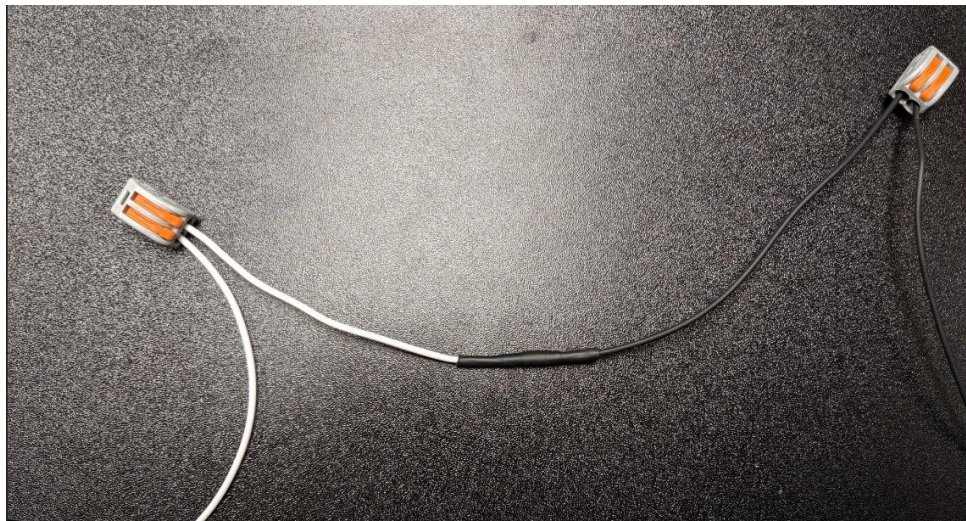

Figure 13: Diode Assembly Connected to Coach Heater Line

- 11) Locate the heating pad cutout under the pack. Completely clean the area where the heating pad will be adhered, along with the surrounding area. A degreasing solvent and clean cloth should be used to prepare the area. Remove the backing from the heating pad and attach it to the pack. Place the heating pad in the center square opening of the battery pack bracket (Figure 14). **Note: Area must be completely clean for the heating pad and RTV to adhere**

to the pack. Failure to clean the surface completely could cause failure of the heating pad.

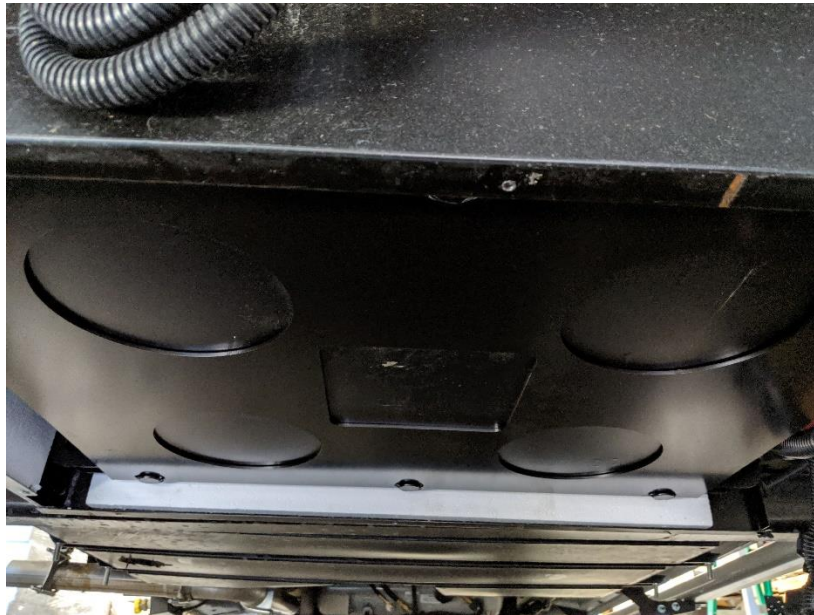

Figure 14: Square Cutout for Heating Pad Location

12) Apply RTV sealant to completely cover the edges of the heating pad (Figure 15).

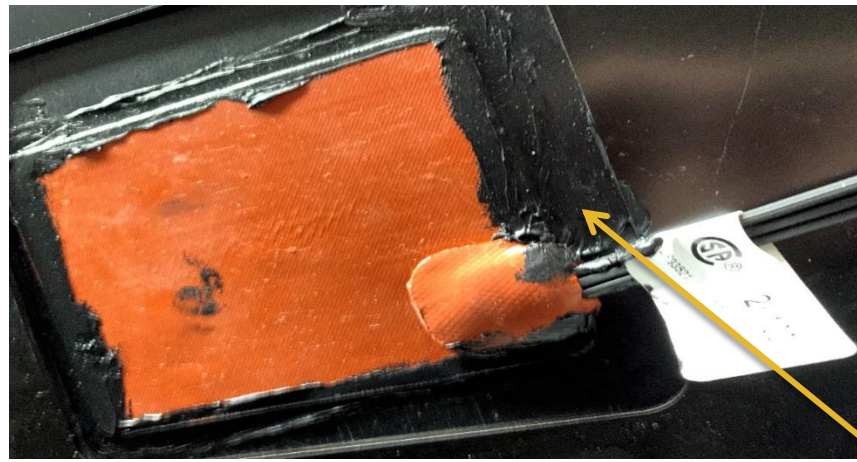

Figure 15: RTV Sealant Application

13) Reinstall the pack 14 pin trunk connector and return the key to "On" position.

14) Take the fiberglass pieces from the heating pad kit and lay them on the lower battery access panel. The fiberglass should be placed in a cross pattern with the

overlapping section of fiberglass matching up with the point where the heating pad will contact the panel (Figure 16).

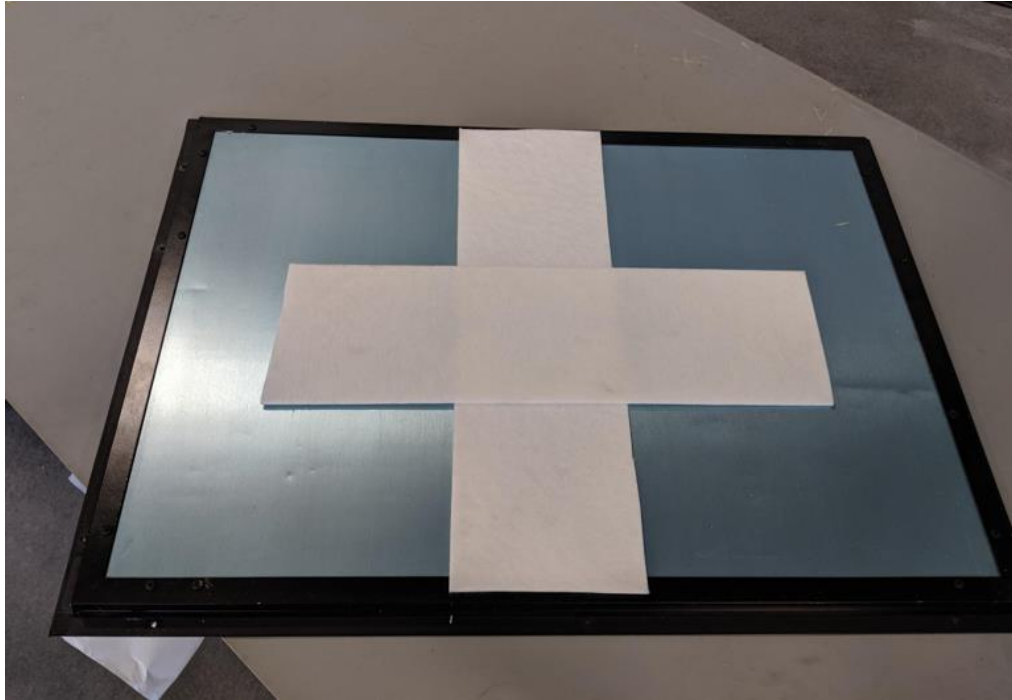

Figure 16: Fiberglass Position on Pack Side of Lower Access Panel

15) Carefully reinstall the lower battery panel, ensuring the fiberglass remains in position and is pressed firmly against the heating pad. Reinstall the side access cover to its original position (Figure 16).

16) Confirm all parts have been replaced and returned to their proper position.



Warning: *Improper wiring or connections could result in system damage, injury, vehicle damage, or failures not covered under warranty.*



Warning: *Heating elements should not be located directly on, or near, combustible materials. Doing so causes a risk of fire, injury, or damage to the system or vehicle.*

5.0 GL INSTALLATION

- 1) To begin installation, start by ensuring the Volta system has been powered off, along with the vehicle. Next, locate the Volta Pack access cover, which is positioned under the vehicle, behind the rear axle (Figure 17,18).

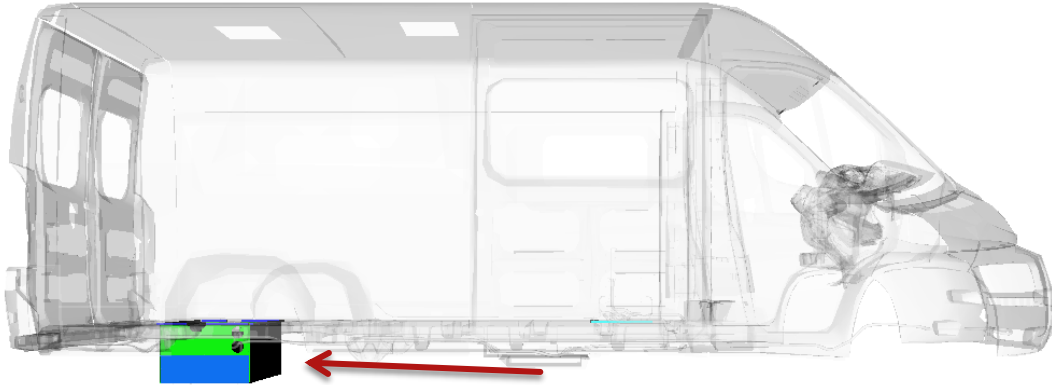

Figure 17: Volta Pack Location

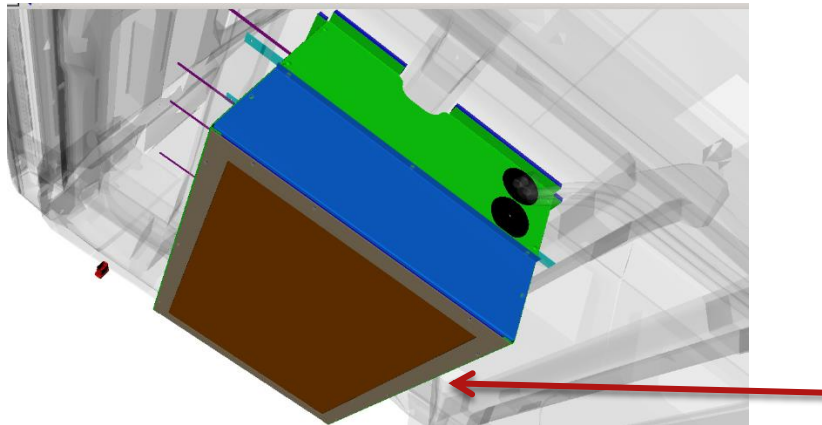

Figure 18: Volta Pack Access Cover (Blue) and Lower Battery Panel (Brown)

- 2) Uninstall the access cover by using a Phillips-head screwdriver to remove the 8 mounting screws.

- 3) Turn the pack key into the vertical, OFF, position and remove it until the end of the modification (Figure 19). Then disconnect the round trunk connector from the pack (Figure 20).



Figure 19: Key in vertical "Off" Position



Figure 20: Round Pack Trunk Connector

- 4) Remove the *lower panel* from the battery case that is held in-place with 9 Phillips-head screws (Figure 18).
- 5) On the inside of the vehicle, remove the seat that covers the Volta inverter/charger. To uninstall the bench top, remove the 4 Phillips-head screws and lift the seat straight up (Figure 21).

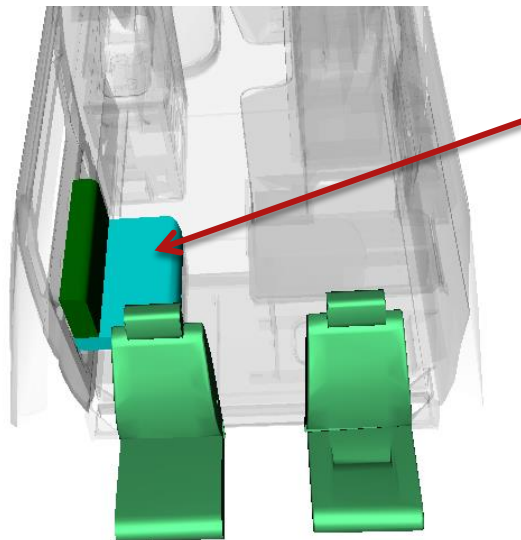

Figure 21: Bench Seat Location

Inside the seat compartment, locate the grommet installed in the floor (Figure 22). Next, locate the same grommet from the underside of the vehicle and make a small incision. The incision should be only large enough for the extension cord wire to be fed through (Figure 23). **Caution should be taken to ensure no wires are cut in the process.**



Warning: Partially, or completely, cutting wire(s) in the electrical system could cause system malfunction and/or fire hazards in the vehicle.

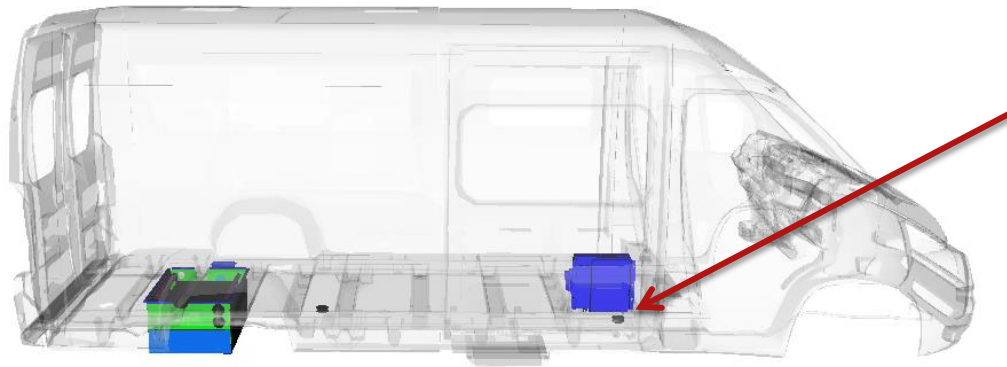

Figure 22: Front Grommet Location



Figure 23: Front Grommet with Incision for Extension Cord

- 6) Once the grommet has enough room, locate the 20' extension cord from the Volta Heating Pad Kit. Cut the cable around 1 ft away from the female connector end (Figure 24). Run the cut end of the 20' extension cable through the opening, leaving the male connector end near the inverter/charger (where it can be plugged into the GFCI outlet).



Figure 24: Location to Cut AC Extension Cord

- 7) Next, locate the heater box connector, directly underneath the kitchen sink (Figure 25). To access the connector, remove the detachable cabinet panel from below the sink.



Figure 25: Existing Vehicle Heater Box Connector

- 8) Underneath the vehicle, locate the grommet that feeds into the undersink cabinet from the vehicle. Using a utility knife, carefully cut the grommet enough to feed the 2 pin heater box connector through (Figure 26,27). **Caution should be taken to ensure no wires are cut in the process.** Run the 2 Conductor Heater Line Extension through the grommet with the mating connector in the sink compartment.

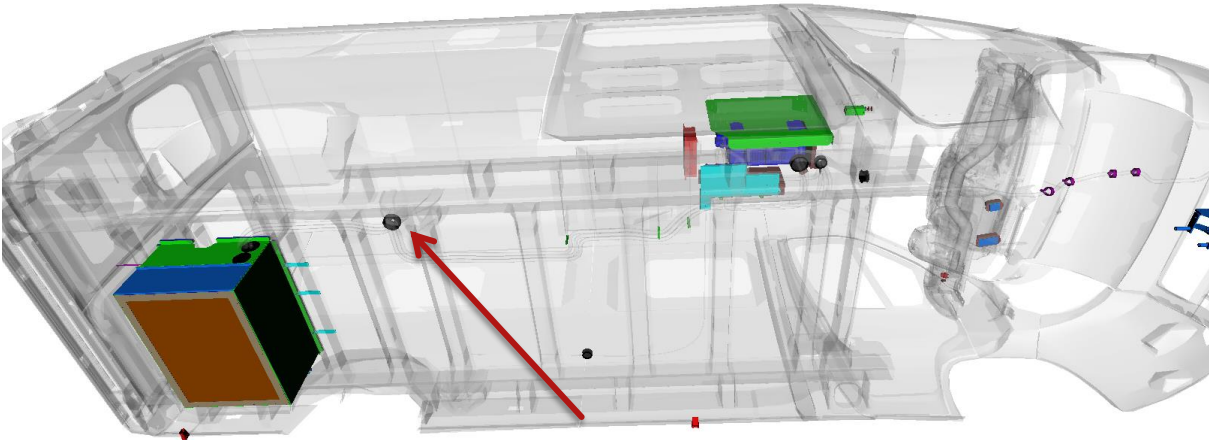

Figure 26: Location of Grommet Under Sink



Figure 27: Loomed Wires Through Sink Grommet



Warning: Partially, or completely, cutting wire(s) in the electrical system could cause system malfunction and/or fire hazards in the vehicle.

- 9) Take the remainder of the 2 *Conductor Heater Line Extension*, and the extension cord, and run the cables with the existing wire bundles beneath the vehicle to the battery pack. Make a final incision in the lower battery pack grommet and feed both wires through (Figure 26). **Caution should be taken to ensure no wires are cut in the process.**



Warning: Partially, or completely, cutting wire(s) in the electrical system could cause system malfunction and/or fire hazards in the vehicle.

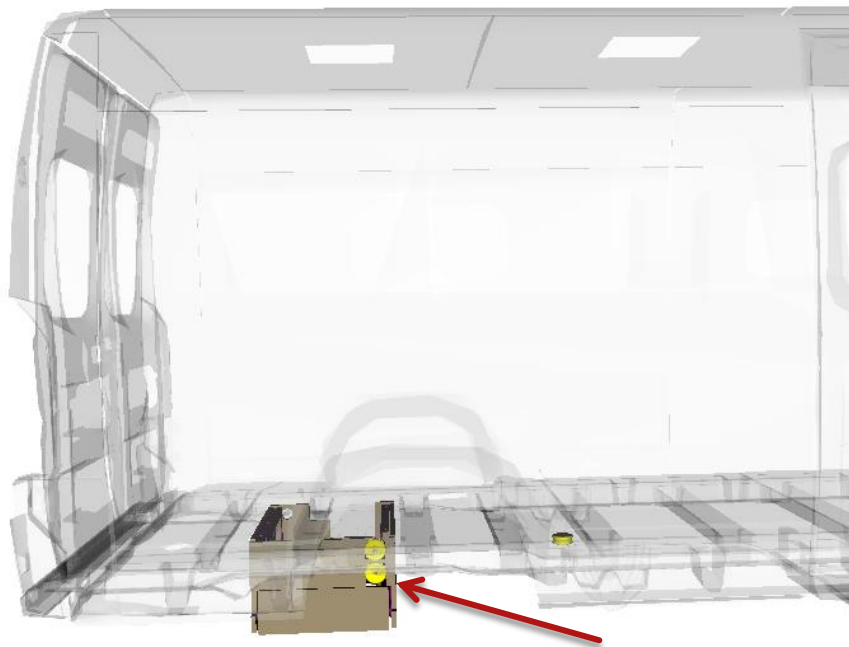

Figure 28: Location of lower battery pack grommet

- 10) Remove the interior vehicle battery access panel, by removing the 4 Phillip's-head screws (Figure 29,30).



Figure 29: Interior battery pack access panel



Figure 30: Interior battery pack access panel removed.

- 11) Completely clean the area where the heating pad will be adhered, along with the surrounding area. A degreasing solvent and clean cloth should be used to prepare the area. Remove the backing from the heating pad and attach it to the pack with the cord facing the front of the pack (end of the pack where the key is located). Place the heating pad in the center square opening of the battery pack bracket (Figure 31). **Note: Area must be completely clean for the**

heating pad and RTV to adhere to the pack. Failure to clean the surface completely could cause failure of the heating pad.

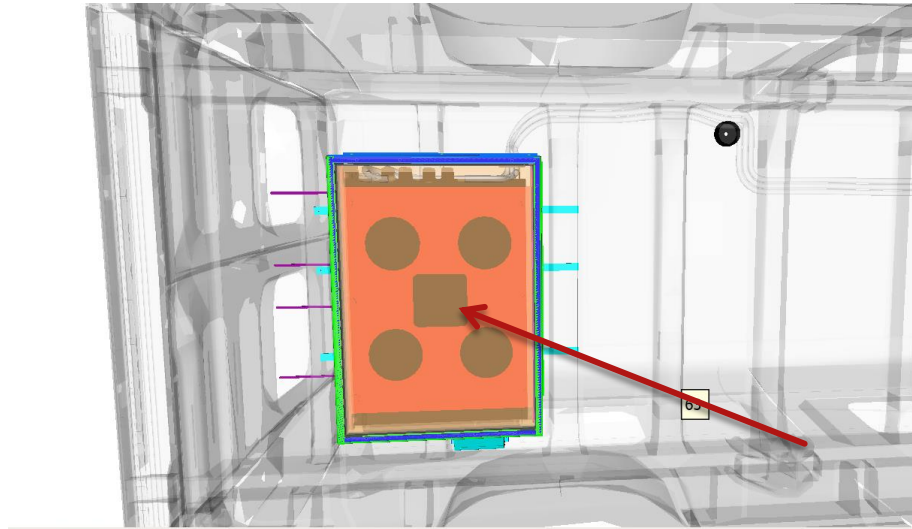

Figure 31: Heater Pad Location on Pack

12) Apply RTV sealant to completely cover the edges of the heating pad (Figure 32).

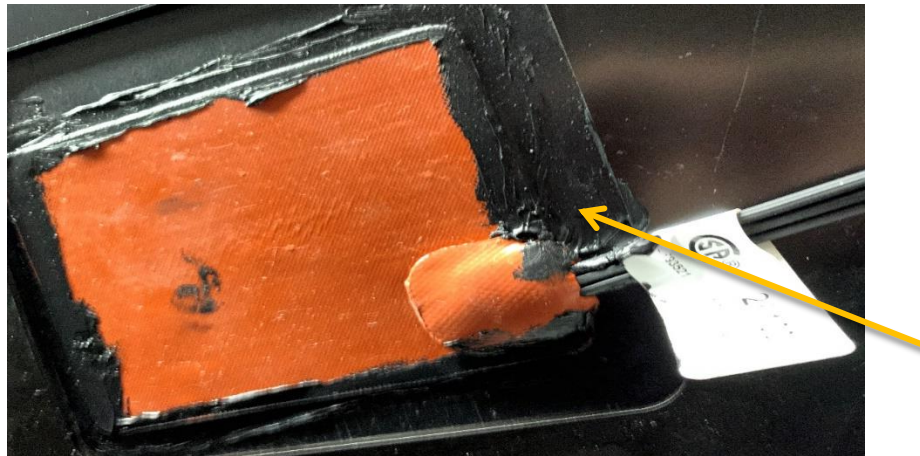

Figure 32: RTV sealant application to heating pad

13) Feed the heating pad cable through the grommet with the extension cord and 2 Conductor Heater Line Extension. Ensure all three cables are fed through the grommet, passthrough, and into the cabinet area inside the vehicle.

14) Place split loom over the entire length of cables that were run under the vehicle, including over the rear axle. Use 3/8" split loom for the extension cord and 1/4" split loom for the heater line extension. Once the loom has been installed, secure

it using zip ties every 6-12". Ensure that all wires are in main vehicle harness bundle (Figure 33).



Figure 33: New Wiring Zip Tied to Existing Harness

15) Using the provided wood screws, mount the heater box to the compartment floor (Figure 34).



Figure 34: Mounted Heater Box Location

16) Using the cut end of the extension cord, wire the grounded AC female plug (Figure 35). Match the color of wires to those called out on the interior of the plug. Before closing the plug, flip the cord grip inserts over to the larger setting (Figure 36,37).



Figure 35: Extension Cord Wired to the AC Female Plug



Figure 36: Cord Grip Insert Removed for Adjustment



Figure 37: Black Cord Grip Adjusted to Correct Position

17) Connect the Heater 2 Conductor Heater Line Extension to the heater box. Ensure connector is fully seated and locked into place. Connect the male 3-prong AC connector from the heater box to the female connection from the extension cord (Figure 38).



Figure 38: Heater Box Plugged into Extension

18) Tuck all wiring back into the cabinet and replace the access panel (Figure 39).



Figure 39: Installed heater box with wires placed inside access panel

19) Connect the other end of the heater line extension into the 2-pin connector under the sink (Figure 40). Ensure connector is fully seated and locked into place.

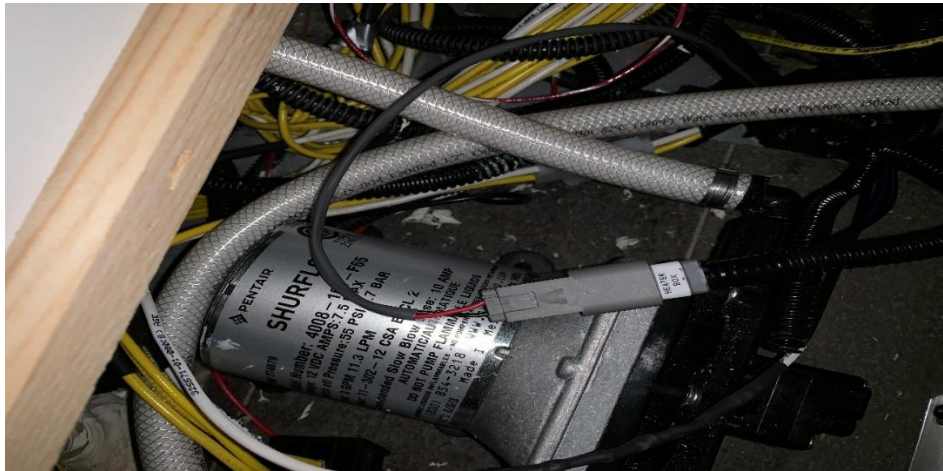

Figure 40: Fully seated heater box connector

20) Under the sink, find the black to white spliced wire labeled "Coach Heater" (Figure 41). Remove the butt splice by cutting both side of the wire. Strip the ends of both the white and black wire.

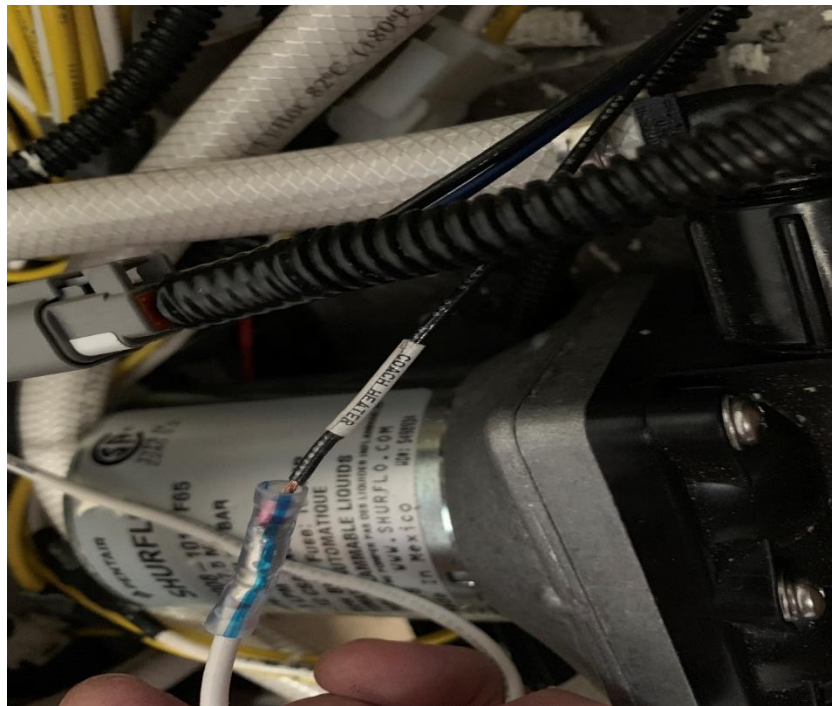

Figure 41: Coach Heater line

21) Take the diode assembly, included in your kit, and align the white and black wires to match the same colored wire in the vehicle (Figure 42,43). Pull the orange tabs up on the unused Wago connector terminals. Insert the stripped

wire ends from the vehicle into the corresponding connector terminal. Pull the orange levers down to lock in the connection (Figure 43). Replace the panel below the sink compartment.



Figure 42: Diode assembly included in kit

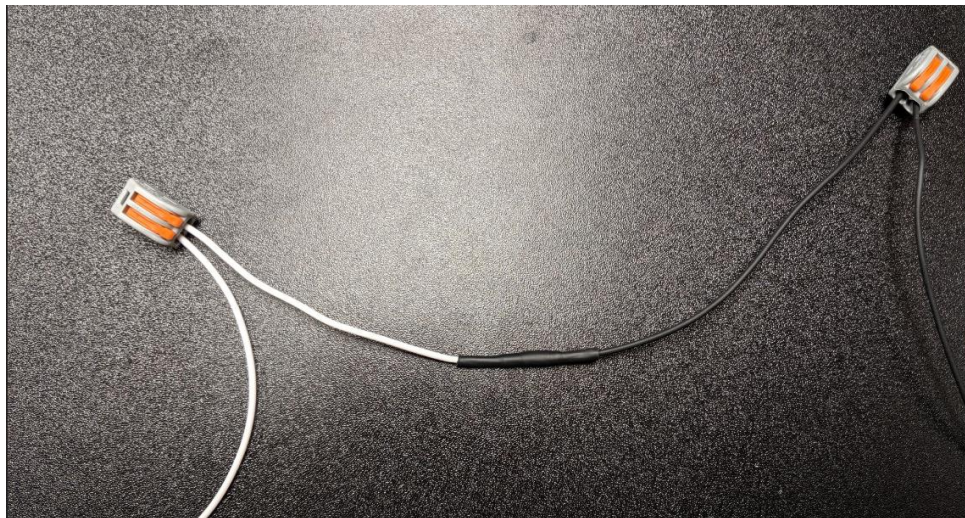

Figure 43: Diode assembly as attached in vehicle

23) Return to the bench seat and plug the male end of the extension cord into the inverter charger outlet. Replace the bench seat in the vehicle (Figure 44).

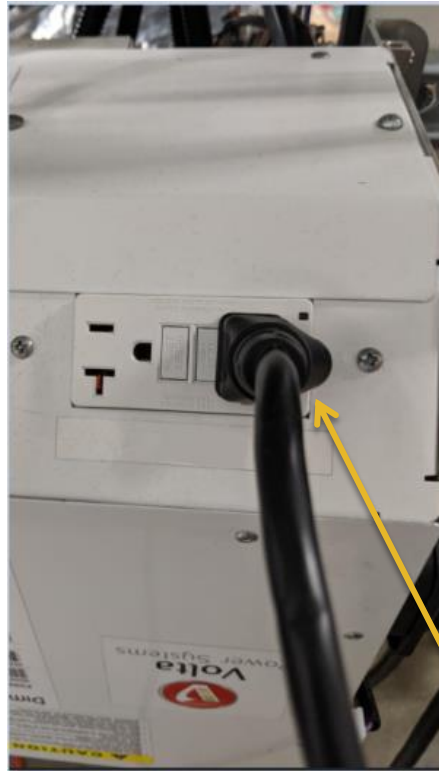

Figure 44: Extension cord plugged into GFCI outlet on inverter/charger



Figure 45: RTV sealant applied to grommet area

24) From the underside of the vehicle, apply RTV sealant around all grommets that were cut during the install process (Figure 45). **Ensure complete coverage during application.** The RTV sealant will act as the main gateway to prevent external elements from entering the vehicle, therefor complete coverage is critical.

25) Reinstall the pack 14 pin connector and return the key to the “On” position.

26) Take the fiberglass pieces from the heating pad kit and lay them on the lower battery access panel. The fiberglass should be placed in a cross pattern with the overlapping section of fiberglass matching up with the point where the heating pad will contact the panel (Figure 46).

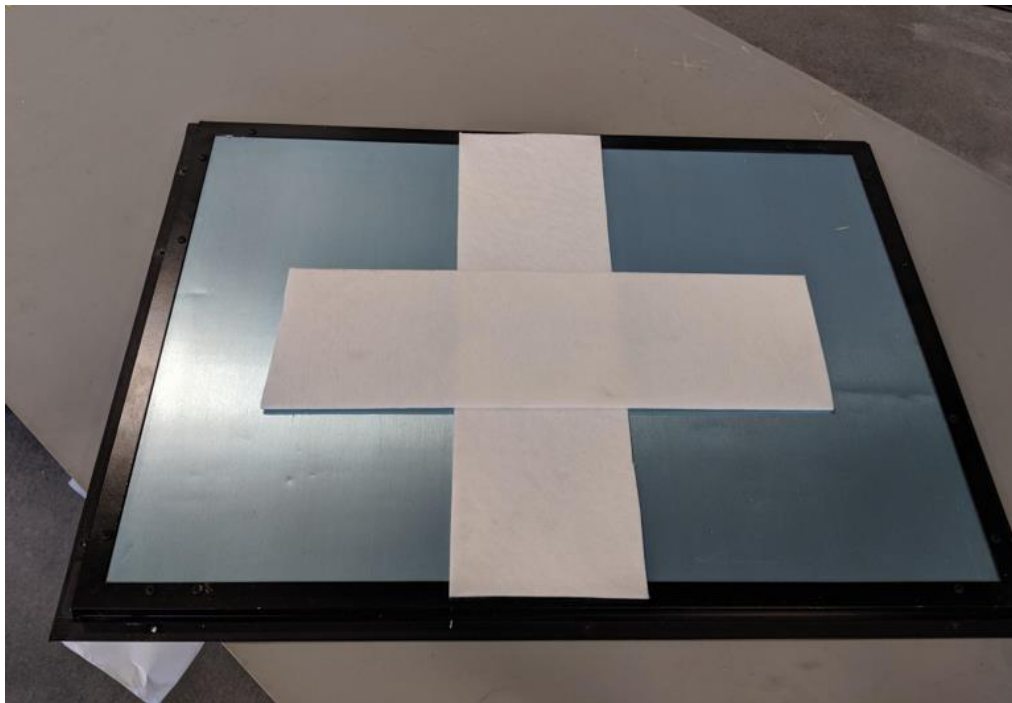

Figure 46: Cross Pattern of Fiberglass on Interior Side of Pack Access Panel

27) Carefully reinstall the lower battery panel, ensuring the fiberglass remains in position and is pressed firmly against the heating pad. Reinstall the side access cover to its original position (Figure 18).

28) Confirm all parts have been replaced and returned to their proper position.



Warning: *Improper wiring or connections could result in system damage, injury, vehicle damage, or failures not covered under warranty.*



Warning: *Heating elements should not be located directly on, or near, combustible materials. Doing so causes a risk of fire, injury, or damage to the system or vehicle.*